

Driven by  
engineering excellence.



WB 1011852 / 07.2008 - We reserve the right to make technical changes.

► [www.sortimo.co.uk](http://www.sortimo.co.uk)

**Sortimo**<sup>®</sup>

Sortimo International Limited  
Old Sarum Park · Salisbury · Wiltshire SP4 6EB  
Freephone 08000 27 5644  
Phone +44 (0) 1722411585  
Fax +44 (0) 1722320831  
vanrack1@sortimo.co.uk

*Sortimo*<sup>®</sup>  
inside

**LDV**

**Sortimo**<sup>®</sup>

with Sortimo's unique racking solution



A place for everything ...



# Form, Function, Flexibility.



## Superior storage.

### Your LDV commercial vehicle and Sortimo Globelyst.

You have chosen a LDV because it suits your space requirements, and has the quality you need for your trade and service. Globelyst the innovative in-vehicle equipment from Sortimo has less weight due to an Alu-Space-Frame structure. This gives your LDV better space and weight utilization. With our starter kit you can organize your vehicle for more efficient use.

You can personalize your Sortimo system exactly to your own requirements at any stage by choosing from the range of Sortimo accessories.



### Alu-Space-Frame Architecture

Weight reduction has always occupied Sortimo. Especially when stability and strength are required, Sortimo sets new standards.

### Floor and wall protection

Soboflex Safety Flooring, Sowaflex Wall & Door kits protect your investment and your vehicle against internal damage. Sortimo racking is secured into the Safety Flooring & not the vehicle's floor pan, making re-installation easier, providing a proven Crash Tested Foundation which avoids the need to drill through the vehicle.

### Variations on a theme – as an individual

There is no need to compromise. Even your most exclusive needs can be met with our Sortimo Globelyst system. Irrespective of the combinations chosen, Globelyst offers the perfect vehicle racking solution at a competitive price, coupled together with the highest safety standards.



**S-Boxes**

**M-Boxes**

**Drawers**

**Component & tool service cases**

**Sobogrip/Soboflex Safety floor**

**Sowaflex wall protection and front cover**

# LDV Maxus SWB



## Passenger side.

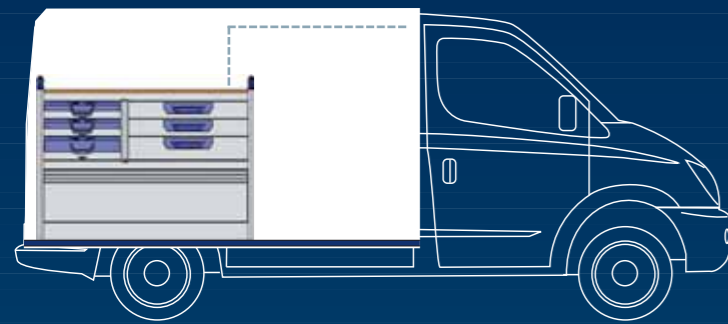

### flooring

By securing the racking into Sortimo's CNC milled Sobo-safety flooring (not the van's floor pan) installation is quicker, easier & best insures your safety in the event of an accident.



**MSS L1-1**

**Description:** Alternative to wood

- ▶ aluminium uprights
- ▶ 3 aluminium open trough shelves
- ▶ kick plate & polyprop ends

**Dim:** (H x W x D) 1260 x 1250 x 385 mm  
**Weight:** 19 kg



**MSS L1-2**

**Description:** Shelves + Boxes

- ▶ aluminium uprights
- ▶ 7 slide-out 'S'boxes
- ▶ 2 alu open shelves with mats & dividers
- ▶ lift-up wheel arch cover & polyprop ends

**Dim:** (H x W x D) 1260 x 1250 x 385 mm  
**Weight:** 30 kg



**MSS L1-3**

**Description:** Boxes

- ▶ aluminium uprights
- ▶ 9 slide-out 'M'toolboxes
- ▶ 2 slide-out 'M'toolboxes
- ▶ 2 large & 2 small Euro boxes
- ▶ lift-up wheel arch cover & polyprop ends

**Dim:** (H x W x D) 1260 x 1250 x 385 mm  
**Weight:** 35 kg



**MSS L1-4**

**Description:** Workbench

- ▶ aluminium uprights
- ▶ HD wooden work surface
- ▶ 1 component & 2 tool service cases mounted on runners
- ▶ 3 drawers with mats & dividers
- ▶ lift-up wheel arch cover & polyprop ends

**Dim:** (H x W x D) 940 x 1250 x 385 mm  
**Weight:** 65 kg

## Driver side.

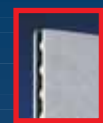
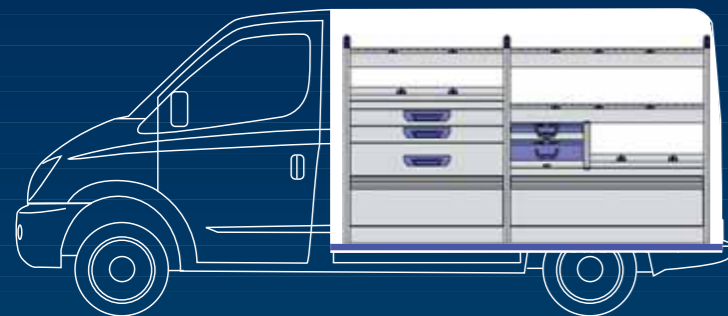

### wall & upper door

Sowaflex wall & door upper protection kits are CNC milled with fittings & locations. Using a honeycomb polyprop construction weight is kept to a minimum, providing an oil & chemical resistant, durable wipe clean finish.



**MSS L1-5**

**Description:** Alternative to wood

- ▶ aluminium uprights
- ▶ 6 aluminium open trough shelves
- ▶ kick plate & polyprop end panels

**Dim:** (H x W x D) 1260 x 2250 x 385 mm  
**Weight:** 29 kg



**MSS L1-6**

**Description:** Shelves + Boxes

- ▶ aluminium uprights
- ▶ 13 slide-out 'S'boxes
- ▶ 4 aluminium open trough shelves with mats & dividers
- ▶ 2 lift-up wheel arch covers & polyprop ends

**Dim:** (H x W x D) 1260 x 2250 x 385 mm  
**Weight:** 48 kg



**MSS L1-7**

**Description:** Boxes

- ▶ aluminium uprights
- ▶ 14 slide-out 'S'boxes
- ▶ 4 slide-out 'M'toolboxes
- ▶ 4 large & 2 small Euro boxes
- ▶ 2 lift-up wheel arch cover & polyprop ends

**Dim:** (H x W x D) 1260 x 2250 x 385 mm  
**Weight:** 59 kg



**MSS L1-8**

**Description:** Drawers + Cases

- ▶ aluminium uprights
- ▶ 5 alu open shelves with mats & dividers
- ▶ 3 drawers with mats & dividers
- ▶ 1 compartment case, 1 tool-case on runners,
- ▶ 2 lift-up wheel arch cover & polyprop ends

**Dim:** (H x W x D) 1260 x 2250 x 385 mm  
**Weight:** 84 kg

All of the above systems use the same Aluminium space-frame, so can be upgraded as your requirements change. Shelf positions can be changed easily a 17mm increments up or down the space point of installation.

Buy any combination of Driver side, Passenger side & Floor, and Save 10%

# LDV Maxus LWB



## Passenger side.

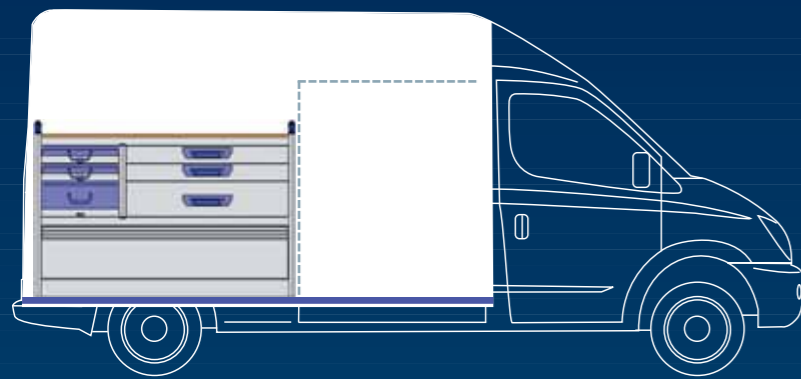

### flooring

By securing the racking into Sortimo's CNC milled Sobo-safety flooring (not the van's floor pan) installation is quicker, easier & best insures your safety in the event of an accident.



**MSL L2-1**

**Description:** Alternative to wood

- ▶ aluminium uprights
- ▶ 4 aluminium open trough shelves
- ▶ kick plate & polyprop ends

**Dim:** (H x W x D) 1600 x 1500 x 485 mm  
**Weight:** 31 kg



**MSL L2-2**

**Description:** Shelves + Boxes

- ▶ aluminium uprights
- ▶ 9 slide-out 'S'boxes
- ▶ 3 alu open shelves with mats & dividers
- ▶ lift-up wheel arch cover & polyprop ends

**Dim:** (H x W x D) 1600 x 1500 x 485 mm  
**Weight:** 45 kg



**MSL L2-3**

**Description:** Boxes

- ▶ aluminium uprights
- ▶ 18 slide-out 'S'boxes
- ▶ 3 slide-out 'M'toolboxes
- ▶ 4 large & 4 small Euro boxes
- ▶ lift-up wheel arch cover & polyprop ends

**Dim:** (H x W x D) 1600 x 1500 x 485 mm  
**Weight:** 63 kg



**MSL L2-4**

**Description:** Workbench

- ▶ aluminium uprights
- ▶ HD wooden work surface
- ▶ 1 component, 2 tool service cases mounted on runners
- ▶ 3 drawers with mats & dividers
- ▶ lift-up wheel arch cover & polyprop ends

**Dim:** (H x W x D) 1000 x 1500 x 485 mm  
**Weight:** 85 kg

## Driver side.

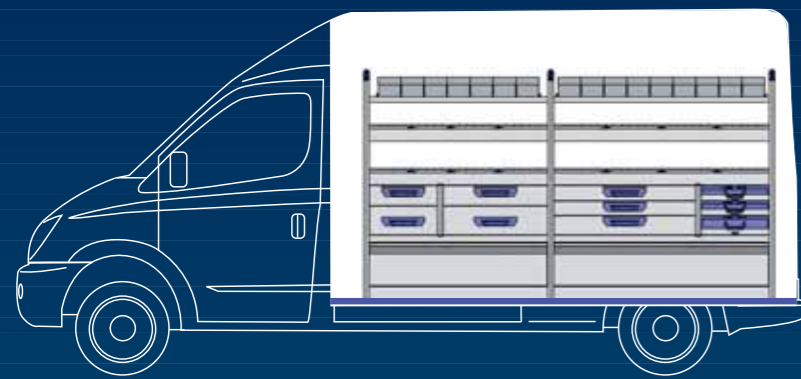

### wall & upper door

Sowaflex wall & door upper protection kits are CNC milled with fittings & locations. Using a honeycomb polyprop construction weight is kept to a minimum, providing an oil & chemical resistant, durable wipe clean finish.



**MSL L2-5**

**Description:** Alternative to wood

- ▶ aluminium uprights
- ▶ 8 aluminium open trough shelves
- ▶ kick plate & polyprop end panels

**Dim:** (H x W x D) 1600 x 2750 x 385 mm  
**Weight:** 41 kg



**MSL L2-6**

**Description:** Shelves + Boxes

- ▶ aluminium uprights
- ▶ 16 slide-out 'S'boxes
- ▶ 6 aluminium open trough shelves with mats & dividers
- ▶ 2 lift-up wheel arch, 4 covers & polyprop ends

**Dim:** (H x W x D) 1600 x 2750 x 385 mm  
**Weight:** 65 kg



**MSL L2-7**

**Description:** Boxes

- ▶ aluminium uprights ▶ 17 slide-out 'S'boxes
- ▶ 5 slide-out 'M'toolboxes
- ▶ 2 open trough shelf with mats & dividers
- ▶ 5 large / 5 medium & 3 small stacked Euro boxes,
- ▶ 2 lift-up wheel arch cover & polyprop ends

**Dim:** (H x W x D) 1600 x 2750 x 385 mm  
**Weight:** 86 kg



**MSL L2-8**

**Description:** Drawers + Cases

- ▶ aluminium uprights ▶ 16 slide-out 'S'boxes
- ▶ 4 aluminium open trough shelves with mats & dividers
- ▶ 7 drawers with mats & dividers
- ▶ 1 compartment case, 2 tool-cases on runners
- ▶ 2 lift-up wheel arch cover & polyprop ends

**Dim:** (H x W x D) 1600 x 2750 x 385 mm  
**Weight:** 126 kg

All of the above systems use the same Aluminium space-frame, so can be upgraded as your requirements change. Shelf positions can be changed easily a 17mm increments up or down the space point of installation.

Buy any combination of Driver side, Passenger side & Floor, and Save 10%

# Sortimo original accessories

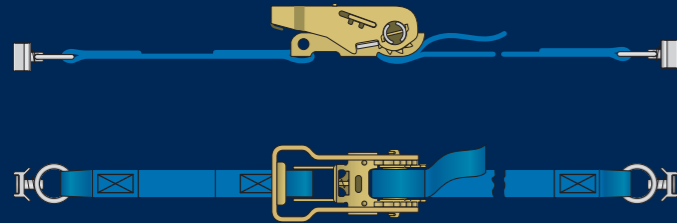

01 ratchet strap to suit tracking

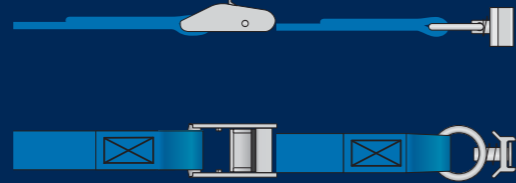

02 pinch strap to suit tracking



19 16 watt 12 v strip light



20 360° swivel for vice



21 vice 120 mm jaws (forged steel)



03 lashing track Q/R eye



04 floor eyelet

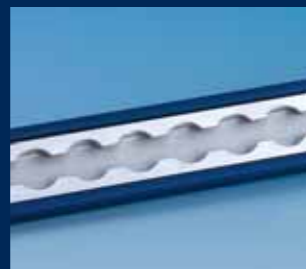

05a end panel lashing track  
05b bulkhead lashing track 1m



06 floor lashing track 1.5m



07 front racket pocket



08 document pocket



09 cable holder



10 perfo hooks - 18 piece set



22 perfo end panel upgrade (without hooks and tools)



23 T-BOXX



11 hook



12 ladder hook



13 coat hook



14 cam clamp



15 cone / holder set



16 paper towel holder



17 waste basket



18a fire extinguisher 2 kg  
18b fire extinguisher 6 kg



24 12 V hot & cold handwash

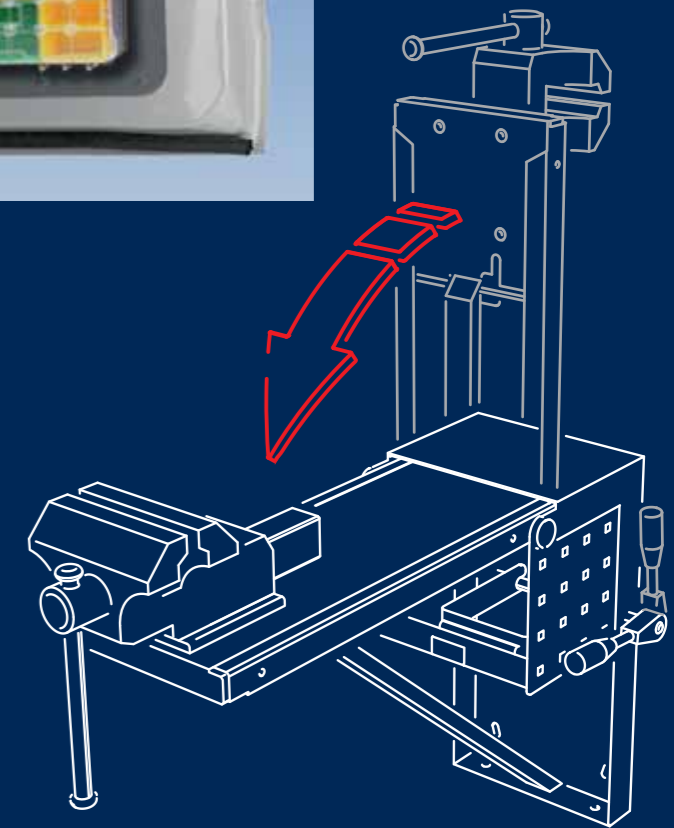

25 drop-down platform without vice, (check suitability)

